

ABSORB-M™ | NON-REDIRECTIVE CRASH CUSHION

P/N ABSORB-M Rev D (ECN 62817)

- ANCHORLESS INSTALLATION, NO FOUNDATION REQUIRED
- EASY TO DEPLOY AND REMOVE
- MASH TL-2 & TL-3 COMPLIANT

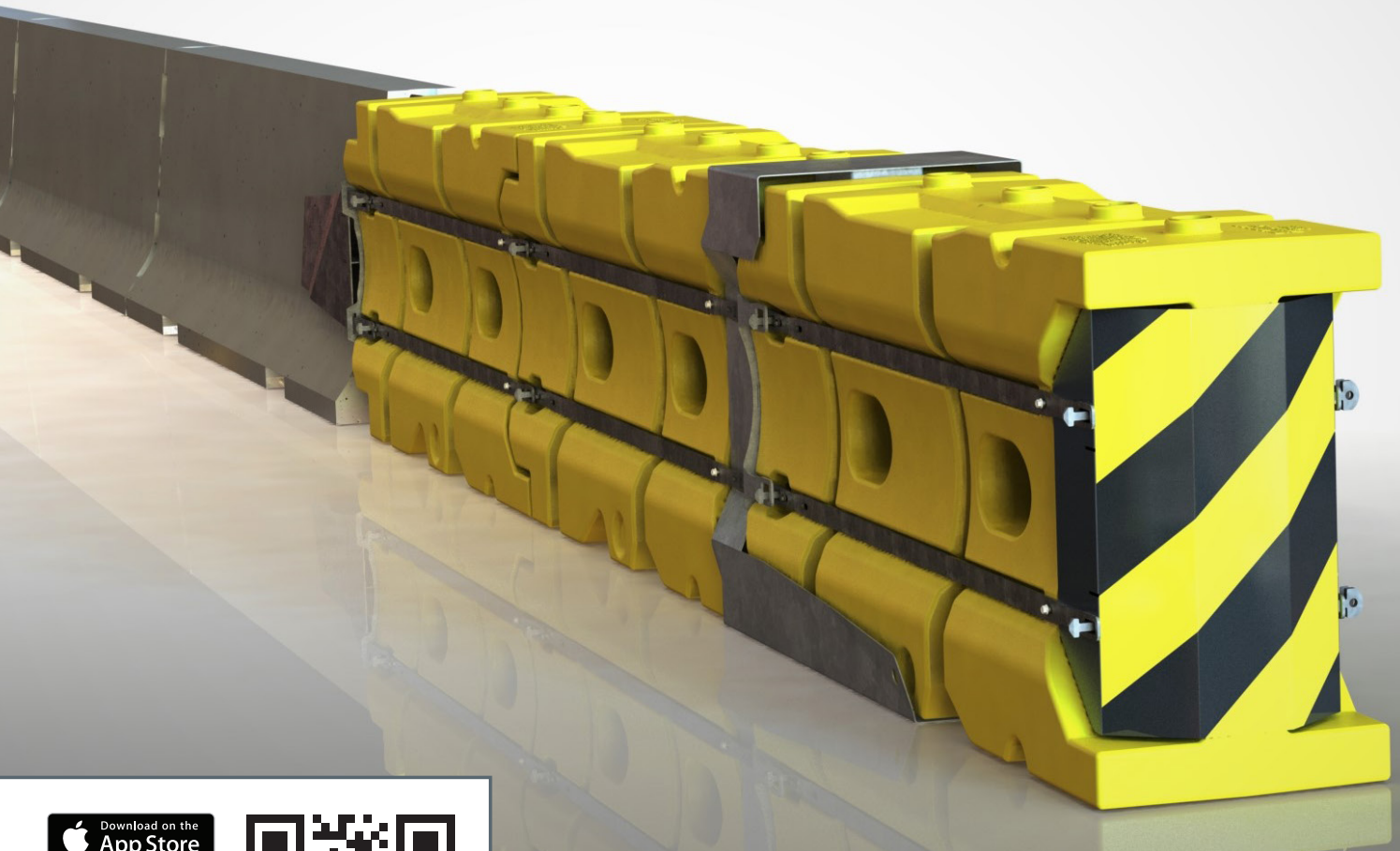

The Lindsay Guide App is available as a free download from the Apple Store® and Google Play™.

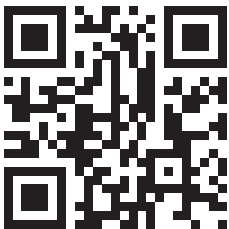

 **LINDSAY™**

REVISIONS				
DATE	ECN	PUBLISHED ECN	REVISION	DESCRIPTION OF CHANGE
08/14/2019	4119	4119	A	New release
05/21/2020	37881	37881	B	BOM item corrections
07/02/2024	62653	62653	C	p.8 - changes to BOM, callouts
09/16/2024	62817	62817	D	p.22, 29 - Additional note, inspection item.

Important For Your Safety

We have provided important safety messages in this manual. **ALWAYS** read and obey all safety messages.

This is the safety alert symbol.



This symbol alerts you to hazards that can kill or hurt you and others. All safety messages will be preceded by the safety alert symbol and the word “DANGER”, “WARNING”, or “CAUTION”.

These words mean:

⚠ DANGER IMMEDIATE HAZARDS THAT WILL RESULT IN SEVERE PERSONAL INJURY OR DEATH.

⚠ WARNING Hazards or unsafe practices that **COULD** result in severe personal injury or death.

⚠ CAUTION Hazards or unsafe practices that **COULD** result in minor personal injury or product or property damage.

This manual must be available to the person(s) overseeing and/or assembling the crash cushion system at all times. For additional copies, or if you have any questions about any portion of this manual, see below to contact Lindsay Transportation Solutions.

Contact Information

Lindsay Transportation Solutions

U.S. Toll Free: (888) 800-3691

or

+1 (707) 374-6800

www.lindsaytransportationsolutions.com

STANDARD LIMITED WARRANTY

Lindsay Transportation Solutions, Inc. (collectively with its parent company Lindsay Corporation and all other subsidiaries and affiliates directly and indirectly owned by Lindsay Corporation, "LTS") has tested the impact performance of certain of its barriers, crash cushion systems, and other highway safety hardware at an ISO-certified crash testing laboratory under controlled conditions pursuant to the test matrix criteria of NCHRP 350, MASH or EN-1317, as applicable, as designated by the American Association of State Highway and Transportation Officials ("AASHTO") and the Federal Highway Administration ("FHWA"), or the European Committee for Standardization ("CEN"). Such tests do not replicate every possible crash scenario and they are not intended to represent the performance of barriers, crash cushion systems, and other highway safety hardware when impacted in every real world impact condition or by every vehicle type. It is widely recognized that there are impact conditions that exceed the performance expectations of all highway safety equipment.

The products with which this limited warranty is provided (the "Products") are intended to be installed, operated, and maintained in a manner not inconsistent with instructional materials provided by LTS, the AASHTO Roadside Design Guide (as applicable), and state and federal guidelines (as applicable). Selection and proper installation, operation, and maintenance of any highway safety product, including the Products, is the responsibility of the highway authority and state department of transportation.

LTS EXPRESSLY DISCLAIMS ANY WARRANTY OR LIABILITY FOR CLAIMS ARISING BY REASONS OF DEATH OR PERSONAL INJURY OR DAMAGE TO PROPERTY RESULTING FROM ANY IMPACT, COLLISION OR HARMFUL CONTACT WITH THE PRODUCTS OR NEARBY HAZARDS OR OBJECTS BY ANY VEHICLE, OBJECTS, OR PERSONS, REGARDLESS OF WHETHER THE PRODUCTS WERE INSTALLED IN CONSULTATION WITH LTS OR BY THIRD PARTIES.

LTS warrants that any Product or component part manufactured by LTS will be free from defects in material or workmanship. LTS will replace free of cost any Product or component part manufactured by LTS that contains such a defect.

THE FOREGOING WARRANTY IS IN LIEU OF AND EXCLUDES ALL OTHER WARRANTIES NOT EXPRESSLY SET FORTH HEREIN, WHETHER EXPRESS OR IMPLIED BY OPERATION OF LAW OR OTHERWISE, INCLUDING BUT NOT LIMITED TO ANY IMPLIED WARRANTIES OF MERCHANTABILITY OR FITNESS FOR A PARTICULAR PURPOSE.

LTS, in its sole discretion, may elect to disclaim the foregoing warranty benefits with respect to (i) any Products that have been inspected and determined by LTS, in its sole discretion, (a) to have been subject to improper storage, accident, misuse, or unauthorized alterations, or (b) that have not been installed, operated, and maintained in accordance with approved procedures and guidelines (including but not limited to instructions included in materials provided by LTS and the AASHTO Roadside Design Guide) and (ii) any components manufactured by the Buyer.

LTS' LIABILITY UNDER THIS WARRANTY IS EXPRESSLY LIMITED TO REPLACEMENT FREE OF COST (IN THE FORM AND UNDER THE TERMS ORIGINALLY SHIPPED), OR TO REPAIR BY LTS, OF PRODUCTS OR PARTS NOT COMPLYING WITH LTS SPECIFICATIONS, OR, AT LTS' ELECTION, TO THE REPAYMENT OF AN AMOUNT EQUAL TO THE PURCHASE PRICE OF SUCH PRODUCTS OR PARTS, WHETHER SUCH CLAIMS ARE FOR BREACH OF WARRANTY OR NEGLIGENCE. LTS SHALL NOT BE LIABLE FOR ANY INCIDENTAL, CONSEQUENTIAL, OR SPECIAL LOSSES, DAMAGES, OR EXPENSES OF ANY KIND, INCLUDING, WITHOUT LIMITATION, ANY SUCH LOSSES, DAMAGES, OR EXPENSES ARISING DIRECTLY OR INDIRECTLY FROM THE SALE, HANDLING, OR USE OF THE PRODUCTS FROM ANY OTHER CAUSE RELATING THERETO, OR FROM PERSONAL INJURY OR LOSS OF PROFIT.

Any claim by the Buyer with reference to Products sold hereunder for any cause shall be deemed waived by the Buyer unless LTS is notified in writing, in the case of defects apparent on visual inspection, within ninety (90) days from the delivery date, or, in the case of defects not apparent on visual inspection, within twelve (12) months from the said delivery date. Products claimed to be defective may be returned prepaid to LTS' plant for inspection in accordance with return shipping instructions that LTS shall furnish to the Buyer forthwith upon receipt of the Buyer's notice of claim. If the claim is established, LTS will reimburse that Buyer for all carriage costs incurred hereunder.

W030587 Rev. 11 revised October 16, 2017



18135 Burke Street, Ste 100 • Omaha, NE 68022 • Tel. +1 (402) 829-6800 • Fax. +1 (402) 829-6334

Table of Contents

Important For Your Safety	3
Contact Information	3
Standard Limited Warranty	4
ABSORB-M™ System Overview.....	6
Recommended Tools.....	7
Safety Equipment	7
Traffic Control.....	7
Parts Identification	8
Bill of Materials.....	10
Preparation	11
Documentation	12
Important Notes.....	13
Anchoring Specifications	14
System Torque Chart	14
Configuration Details.....	15
Step 1 - Transition and Rear Element(s)	16
Step 2 - Transition Straps	17
Step 3 - Midnose and Front Element.....	18
Step 4 - Nose Plate.....	19
Step 5 - Pin Assemblies	20
Step 6 - Transition Strap Anchoring	21
Step 7 - Filling Rear Element(s)	22
System Relocation	23
Option 1 - Transition with the Barrier	24
Option 2 - Transition with the Rear Element	25
Anti-Freeze Solutions	26
Transportation and Storage	28
Inspector Checklist	29
Maintenance Inspection.....	29
Walk-Up Inspections	30
Drawings.....	31
Long-Term Storage.....	35

ABSORB-M™ System Overview

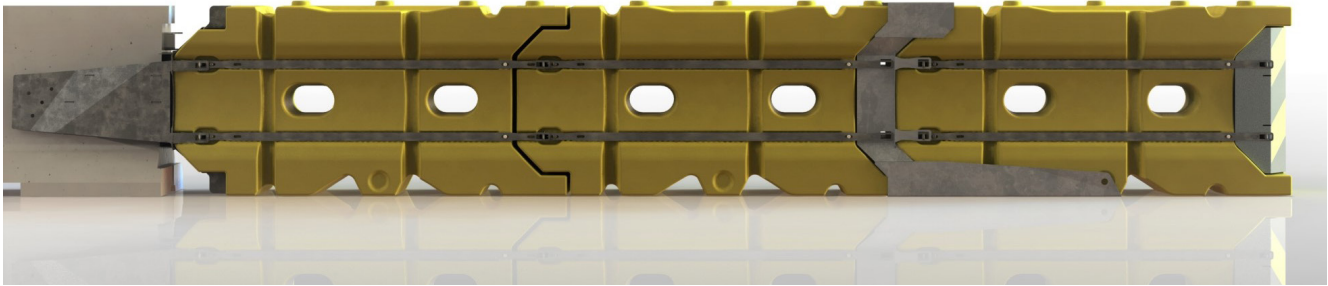

The ABSORB-M™ is a non-redirective, gating, crash cushion designed to meet the latest test standards defined in the *Manual for Assessing Safety Hardware (MASH), Second Edition, 2016*. The ABSORB-M™ system utilizes Tension Straps, a Midnose, a Transition, and water-filled Element Assemblies (Elements) to absorb kinetic energy and safely contain or control the penetration trajectory of impacting vehicles.

The system is comprised of a Nose Plate, Elements, Pin Assemblies (Pins), a Midnose, a Transition, and mechanical anchors. The front Element is always empty with remaining Element(s) full of water. Each Element is pre-assembled with Tension Straps secured with bolts and a thread locking compound.

The system has a nominal 42" height, 24" width, and an effective length of 251-3/4" for TL-3 and 175-3/4" for TL-2. The maximum length of the system, as measured from the Nose Plate to the end of the Transition Strap is approximately 284" for TL-3 and 208" for TL-2.

ABSORB-M™ is designed to accommodate a variety of permanent and portable safety shape, constant slope, and other shapes of barrier up to 42" height.

Recommended Tools

NOTE: The list of tools, safety equipment, and traffic control is a general recommendation and should not be considered a comprehensive list. Depending on the specific characteristics of the job site and the complexity of the repair or assembly, more or less tools may be necessary.

Required Tools

- Tape Measure
- Chalk Line
- Marking Paint
- Rotary Hammer
- Masonry Bit
5/8" (16mm) x 6" (150mm)
- Compressed Air
- 3/4" Diameter Brush
- 1/2" Drive Deep Sockets
15/16" (24mm)
- Impact Wrench
(pneumatic or electric)
- 1/2" Drive Torque Wrench
5 ft-lbf [8 N-m] to 100 ft-lbf [135 N-m]

NOTE: Water source with a flexible hose (maximum 3" diameter) and a minimum 500 Gallon capacity is required for a 3 element, TL-3 system. For cold weather regions, a few typical Anti-Freeze agents are listed on Page 27.

Safety Equipment

- Safety Glasses
- Hearing Protection
- Gloves
- Steel Toe Boots
- Hard Hat
- Safety Vest
- Dust Mask

Traffic Control

- Traffic Control Equipment
- Traffic Control Plan

Parts Identification

⚠ WARNING Use only Lindsay Transportation Solutions parts that are specified by Lindsay Transportation Solutions for use with the ABSORB-M™ System. The use of unspecified parts is prohibited and could result in severe personal injury or death.

Item #	Part #	Description	TL-2	TL-3
2	BSI-1808006-00	ELEMENT ASSEMBLY	2	3

The diagram shows a yellow plastic Element Assembly. Callout 3 points to the top surface. Callout 4 points to a cap on the top surface. Callout 5 points to a plug on the bottom surface. Callout 6 points to a tension strap. Callout 7 points to a C-screw FH 3/8-16 X 1-1/2 GR5 PLT. Callout 8 points to a C-screw FH 3/8-16 X 1 GR5 PLT.

3	BSI-1808002-00*	ELEMENT	2	3
4	BSI-4004494*	CAP	8	12
5	BSI-4004495*	PLUG	2	3
6	BSI-1809053-00*	TENSION STRAP, GALVANIZED	8	12
7	BSI-2001998*	C-SCR FH 3/8-16 X 1-1/2 GR5 PLT	8	12
8	BSI-2001999*	C-SCR FH 3/8-16 X 1 GR5 PLT	8	12

*Components pre-assembled with Element Assembly.

Parts Identification (Cont.)

<p>1</p>  <p>Transition BSI-1809036-00</p>	<p>9</p>  <p>Midnose BSI-1809035-00</p>	<p>10</p>  <p>Nose Plate* BSI-1808014-00</p>			
<p>TL-2, Qty. 1</p>	<p>TL-3, Qty. 1</p>	<p>TL-2, Qty. 1</p>	<p>TL-3, Qty. 1</p>	<p>TL-2, Qty. 1</p>	<p>TL-3, Qty. 1</p>
<p>11</p>  <p>Transition Strap LH BSI-1809037-00</p>	<p>12</p>  <p>Transition Strap RH BSI-1809038-00</p>	<p>13</p>  <p>Pin Assembly BSI-1808005-00</p>			
<p>TL-2, Qty. 1</p>	<p>TL-3, Qty. 1</p>	<p>TL-2, Qty. 1</p>	<p>TL-3, Qty. 1</p>	<p>TL-2, Qty. 8</p>	<p>TL-3, Qty. 10</p>
<p>14</p>  <p>Anchor 5/8-11 x 6 In. BSI-2002001</p>		<p>* Delineation sticker not included. Shown for reference only.</p>			
<p>TL-2, Qty. 6</p>	<p>TL-3, Qty. 6</p>				

Bill of Materials

Item #	Part #	Description	TL-2	TL-3
1	BSI-1809036-00	TRANSITION, GALVANIZED	1	1
2	BSI-1808006-00	ELEMENT ASSEMBLY	2	3
3	BSI-1808002-00*	ELEMENT	2	3
4	BSI-4004494*	CAP	8	12
5	BSI-4004495*	PLUG	2	3
6	BSI-1809053-00*	TENSION STRAP, GALVANIZED	8	12
7	BSI-2001998*	C-SCR FH 3/8-16 X 1-1/2 GR5 PLT	8	12
8	BSI-2001999*	C-SCR FH 3/8-16 X 1 GR5 PLT	8	12
9	BSI-1809035-00	MIDNOSE, GALVANIZED	1	1
10	BSI-1808014-00	NOSE PLATE	1	1
11	BSI-1809037-00	TRANSITION STRAP LH, GALVANIZED	1	1
12	BSI-1809038-00	TRANSITION STRAP RH, GALVANIZED	1	1
13	BSI-1808005-00	PIN ASSEMBLY	8	10
14	BSI-2002001	ANC MECH 5/8-11 X 6 GALV	6	6

*Components pre-assembled with Element Assembly.

Preparation

Foundation

The ABSORB-M™ system is designed to perform on a variety of foundations including concrete, asphalt, and any other surfaces capable of bearing the weight of the system.

Uneven surfaces should be flattened, and large debris removed from the foundation prior to installation.

Cross slopes of up to 8% (5° or 1:12 slope) can be accommodated with the standard hardware and the instructions provided in this manual. For slopes in excess of 8%, contact Lindsay Transportation Solutions Customer Service at (888) 800-3691.

Transition

ABSORB-M™ is designed to accommodate a variety of permanent and portable safety shape, constant slope, and other shapes of barrier up to 42" height.

Placement and installation of the ABSORB-M™ system must be accomplished in accordance with the guidelines and recommendations set forth in the *"AAS-HTO Road Side Design Guide"* FHWA memoranda and other state and local standards.

Before installing the ABSORB-M™ system, ensure that all the materials required for the system are on site and have been identified.

Documentation

Prior to installation and assembly of the ABSORB-M™ system, ensure you have read and understand the installation and assembly instructions. The following items should be reviewed and understood prior to installation.

- Installation and Assembly Manual (check for current revision posted at <http://www.barriersystemsinc.com/> See page 2.
- Installation and Assembly Video, Mobile App - The Lindsay Guide App is available as a free download from the Apple Store® and Google Play™.
- Installation and Assembly Video, Online - Full installation videos can be viewed online at <http://lindsay.guide>
- System Drawings (check <http://www.barriersystemsinc.com/> for current revision, located in installation manual.)

Important Notes

- Sign Convention
 - The term Front = At the Nose Plate
 - The term Rear = At the Transition
- This manual follows installation steps for a complete ABSORB-M™ system that is installed on site or relocated to another location.

⚠ DANGER ABSORB-M™ SYSTEM IS DESIGNED TO BE INSTALLED WITH THE FRONT ELEMENT ALWAYS EMPTY WITH REMAINING ELEMENT(S) FULL OF WATER. FAILURE TO DO SO WILL RESULT IN IMPROPER PERFORMANCE OF THE SYSTEM AND MAY CAUSE SERIOUS BODILY INJURY.

See Page 22 for water filling instructions.

⚠ DANGER IN REGIONS WHERE THE WATER FILLED ELEMENTS COULD BECOME FROZEN, APPROPRIATE ANTI-FREEZE SOLUTIONS SHOULD BE USED. FAILURE TO DO SO WILL RESULT IN IMPROPER PERFORMANCE OF THE SYSTEM AND MAY CAUSE SERIOUS BODILY INJURY.

Care should be taken to ensure that appropriate Anti-Freeze solutions are used in accordance with federal, state, and local requirements. A few typical Anti-Freeze solutions are listed on Page 27.

Anchoring Specifications

The ABSORB-M™ system uses mechanical wedge anchors to secure the Transition Straps to the transition barrier.

Alternative anchorage hardware/methods (epoxy systems or mechanical anchors) may be used such that they meet or exceed the mechanical properties as follows:

	Transition Anchors
Hardware Diameter	5/8"
Pull-out Strength	28,250 lbs
Shear Strength	28,250 lbs

System Torque Chart

Transition Installation*	
Anchor Bolts	60 ft-lbs (80 N-m)

* Using a torque wrench is always the preferred method to tighten hardware for the ABSORB-M™ system, per anchor bolt manufacturer specifications.

Configuration Details

ABSORB-M TL-2 System

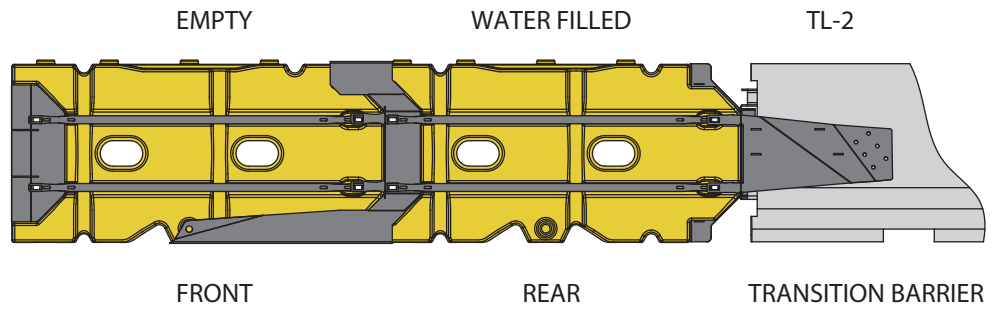

ABSORB-M TL-3 System

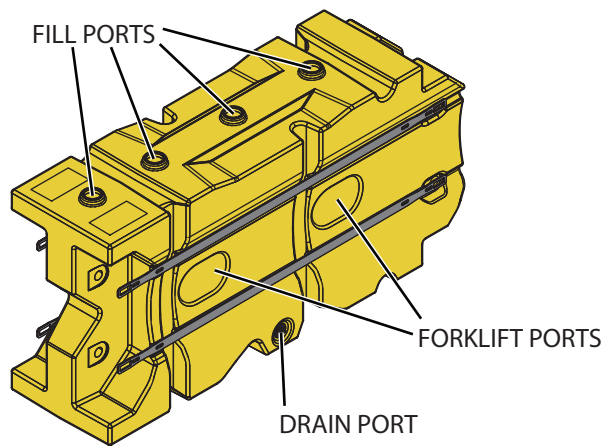
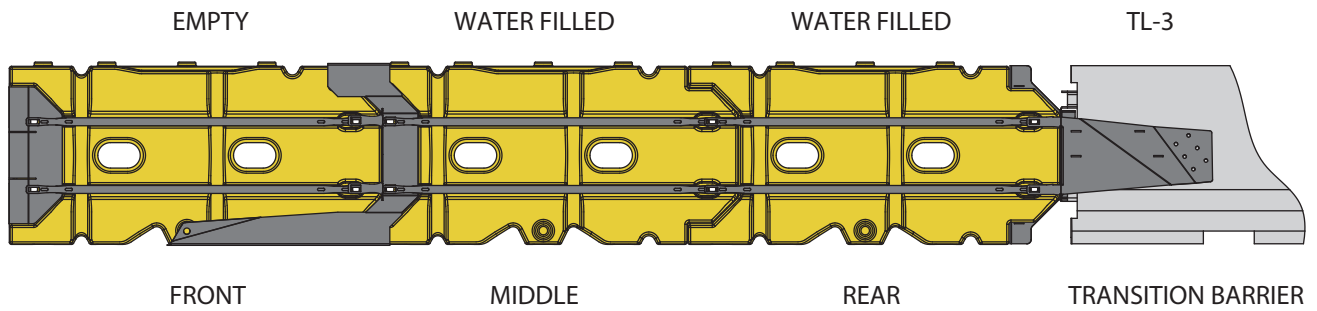

Step 1 - Transition and Rear Element(s)

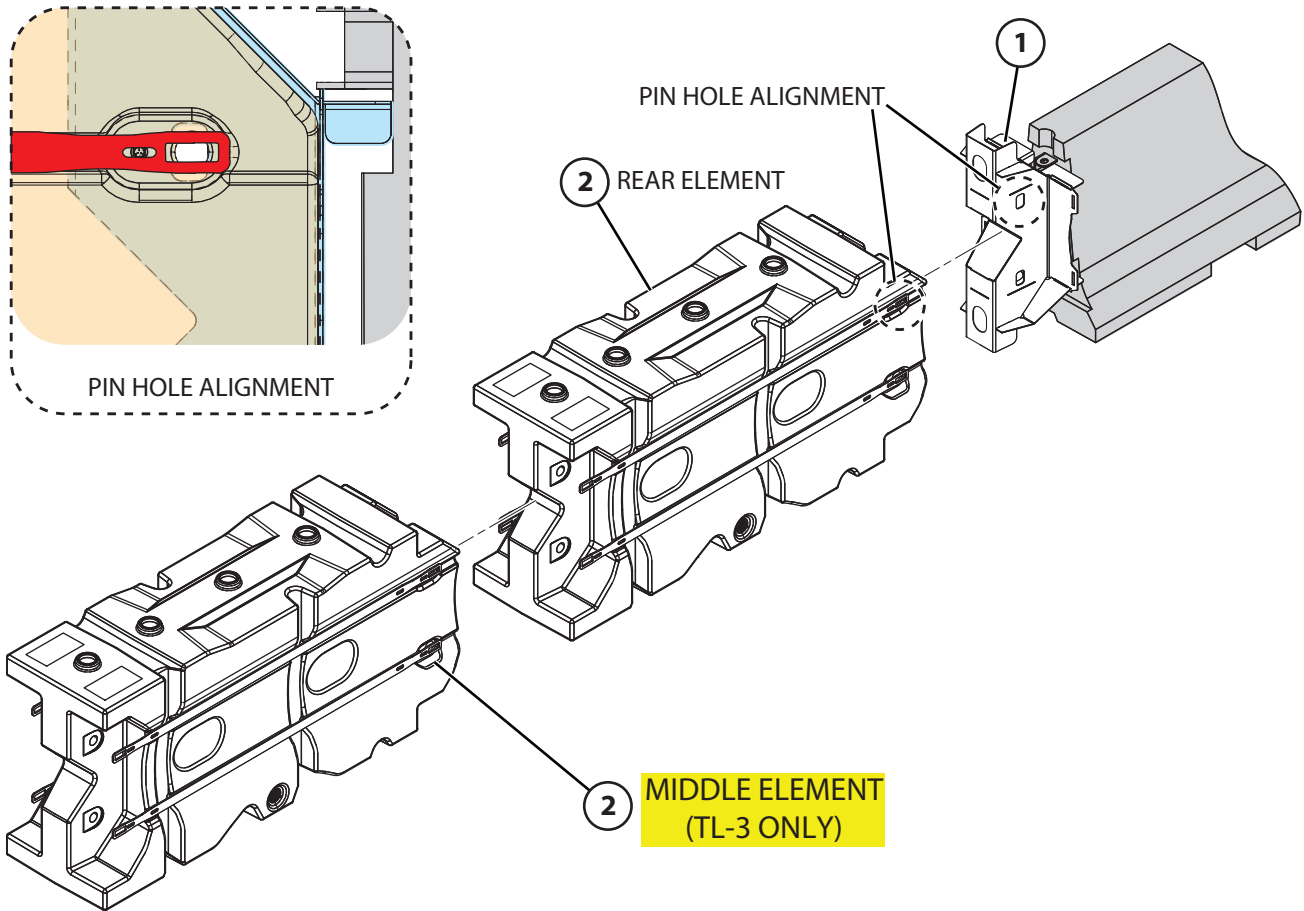

Item #	Part #	Description	TL-2	TL-3
1	BSI-1809036-00	TRANSITION, GALVANIZED	1	1
2	BSI-1808006-00	ELEMENT ASSEMBLY	1	2

- 1.1 Position Transition (item 1) as shown. Ensure the Transition is vertical
- 1.2 Position rear Element (item 2) as shown. Adjust spacing such that center of the pin holes are aligned. For TL-2 systems, skip to Step 2 – Transition Straps
- 1.3 (TL-3 only) Position middle Element (item 2) as shown. Adjust spacing such that center of the pin holes are aligned.

NOTE: For TL-3, Tension Straps of the rear Element should overlap Tension straps of the Middle Element.

Step 2 - Transition Straps

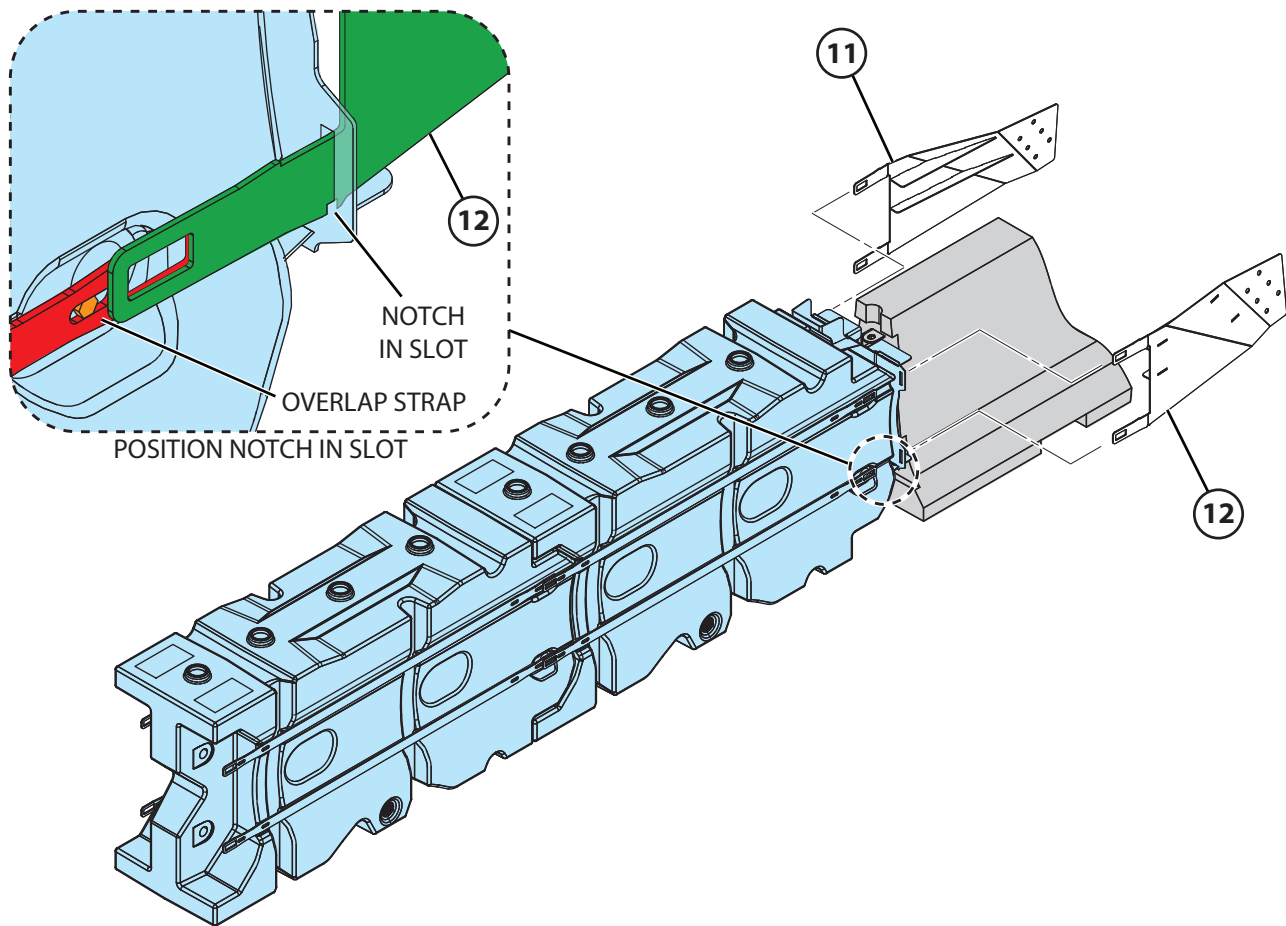

Item #	Part #	Description	TL-2	TL-3
11	BSI-1809037-00	TRANSITION STRAP LH, GALVANIZED	1	1
12	BSI-1809038-00	TRANSITION STRAP RH, GALVANIZED	1	1

- 2.1 Slide corresponding Transition Strap, LH (item 11) and Transition Strap, RH (item 12) through the open slots in the Transition as shown above.
- 2.2 Position each Transition Strap so that the notch in the Pin Tab aligns with the bottom edge of the slot as shown in the section view above.

NOTE: The Transition Strap Tabs should overlap the rear element Tension Strap. The pin holes of the Element, Transition and Transition Straps should all align. If they do not align, reposition the Element and Transition accordingly.

Step 3 - Midnose and Front Element

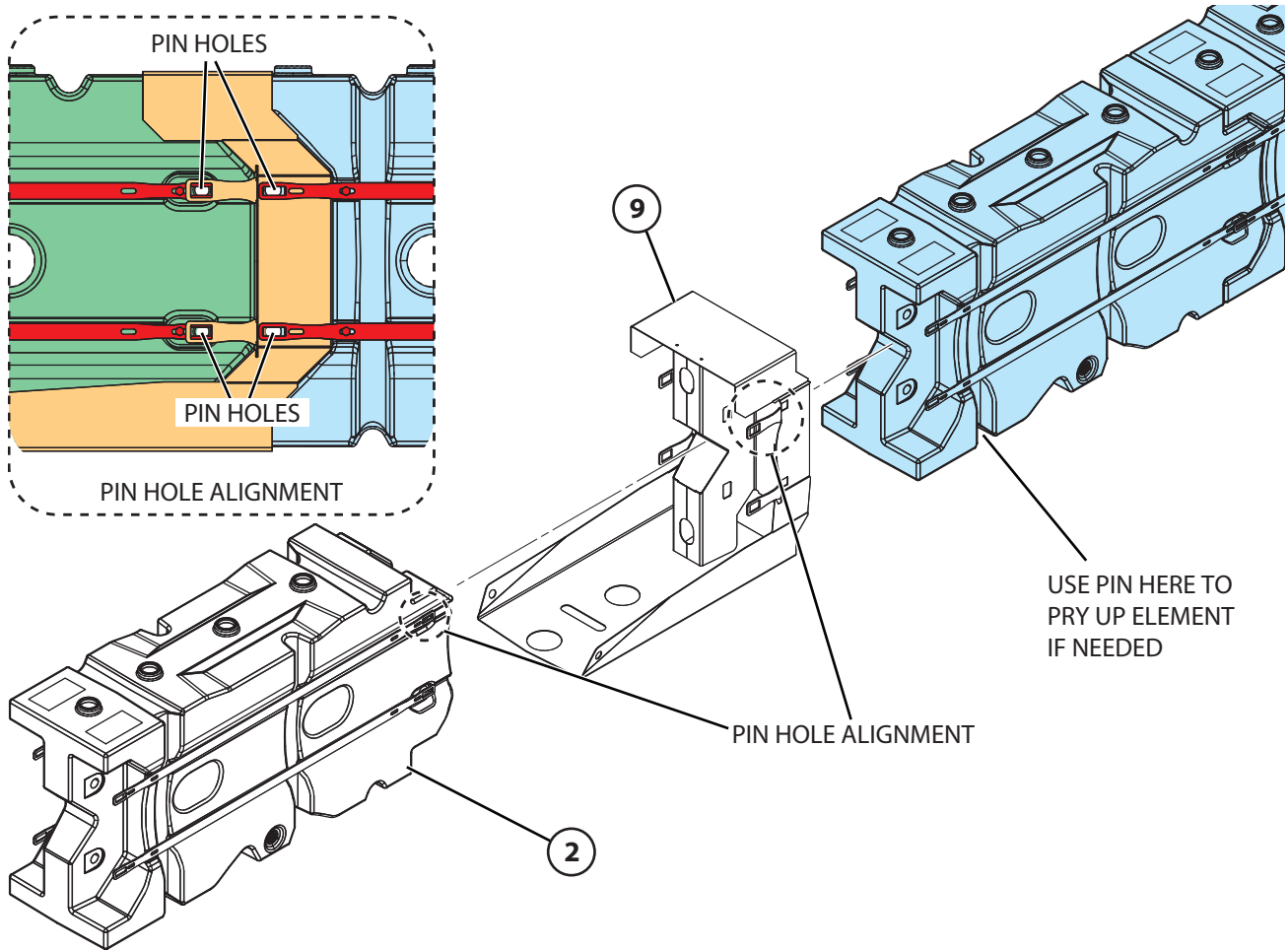

Item #	Part #	Description	TL-2	TL-3
2	BSI-1808006-00	ELEMENT ASSEMBLY	1	1
9	BSI-1809035-00	MIDNOSE, GALVANIZED	1	1

3.1 Slide Midnose (item 9) under the last Element placed. Align the pin holes. Two person lift recommended.

PRO-TIP: A Pin (item 13) can be used to pry up the Element enough to slide the Midnose into position.

NOTE: Tension Straps of the last placed Element should overlap the Midnose.

3.2 Place the front Element (item 2) into the Midnose (item 9). Align the pin holes.

NOTE: Midnose Pin Tabs should overlap the Tension Straps of the front Element.

Step 4 - Nose Plate

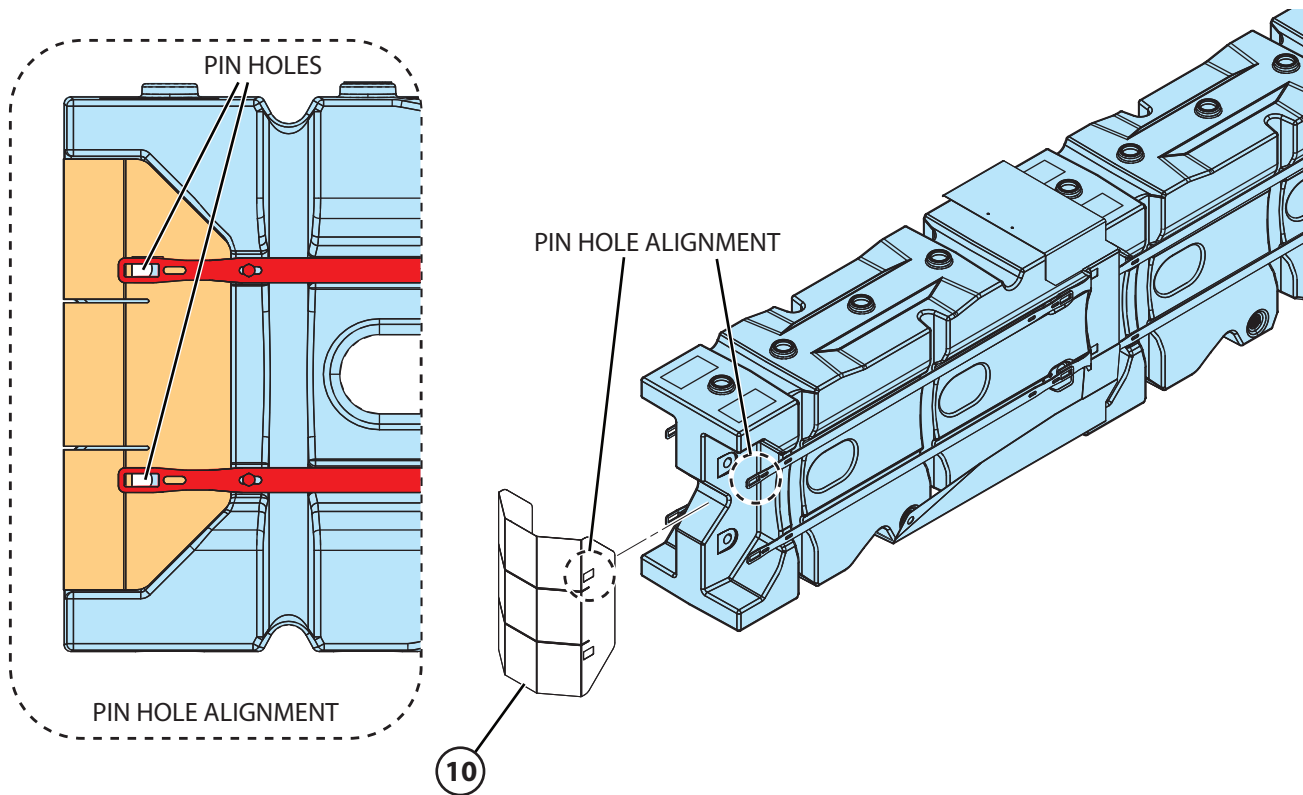

Item #	Part #	Description	TL-2	TL-3
10	BSI-1808014-00	NOSE PLATE	1	1

4.1 Nest Nose Plate (item 10) into the open recess of the front Element. Align pin holes.

NOTE: Tension Straps of the front Element should overlap the Nose Plate.

4.2 Apply delineation decal per federal, state, or local government regulations. Delineation decal NOT included with system.

Step 6 - Transition Strap Anchoring

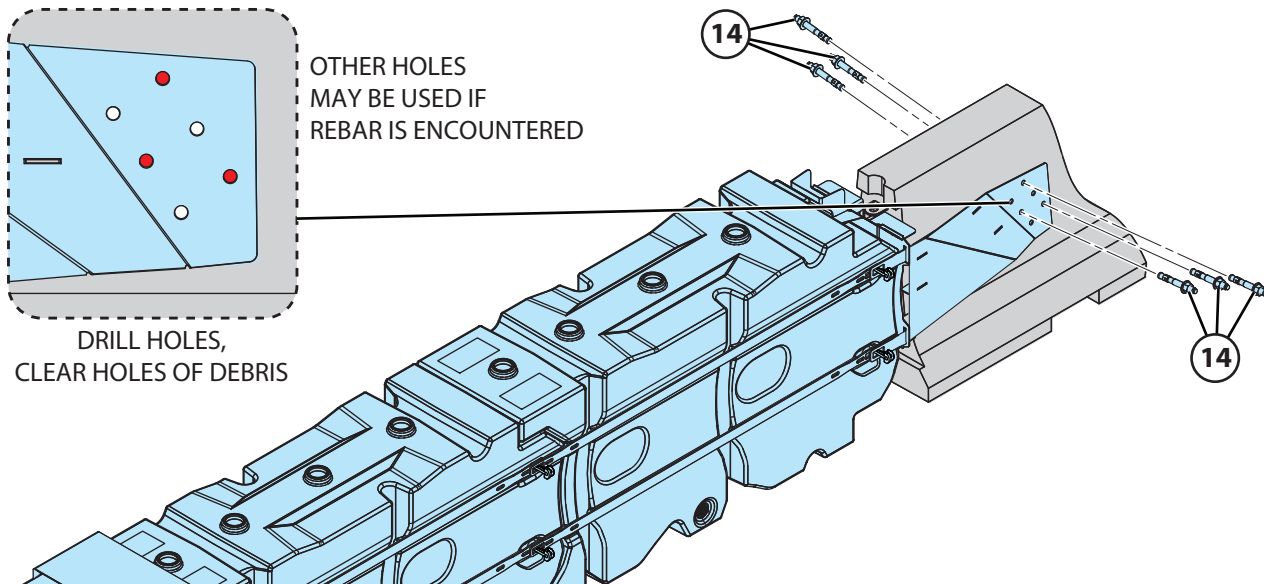

Item #	Part #	Description	TL-2	TL-3
14	BSI-2002001	ANC MECH 5/8-11 X 6 GALV	6	6

Barrier Anchor Depth
3-3/4" [10 cm]

- 6.1 Upon completion of the previous steps, mark and drill into the barrier for 3 of 6 holes per transition strap. Drill 5/8" hole diameter for mechanical anchors.
- 6.2 Clear holes of debris with compressed air and brush. Wear PPE.

CAUTION Wear proper PPE when clearing debris. This operation produces silica dust.

DANGER HOLES MUST BE DRILLED TO DEPTH AND CLEARED OF DEBRIS TO ENSURE RECOMMENDED ANCHORAGE IS ACHIEVED.

- 6.3 Insert anchors (item 14). **Torque to 60 ft-lbs (80 N-m).**

PRO-TIP: Pre-assemble anchor hardware kit with 3-4 threads minimum on top of the nut.

NOTE: If using alternative anchoring, install per manufacturer's recommendation. See Page 14 for anchor specifications.

Step 7 - Filling Rear Element(s)

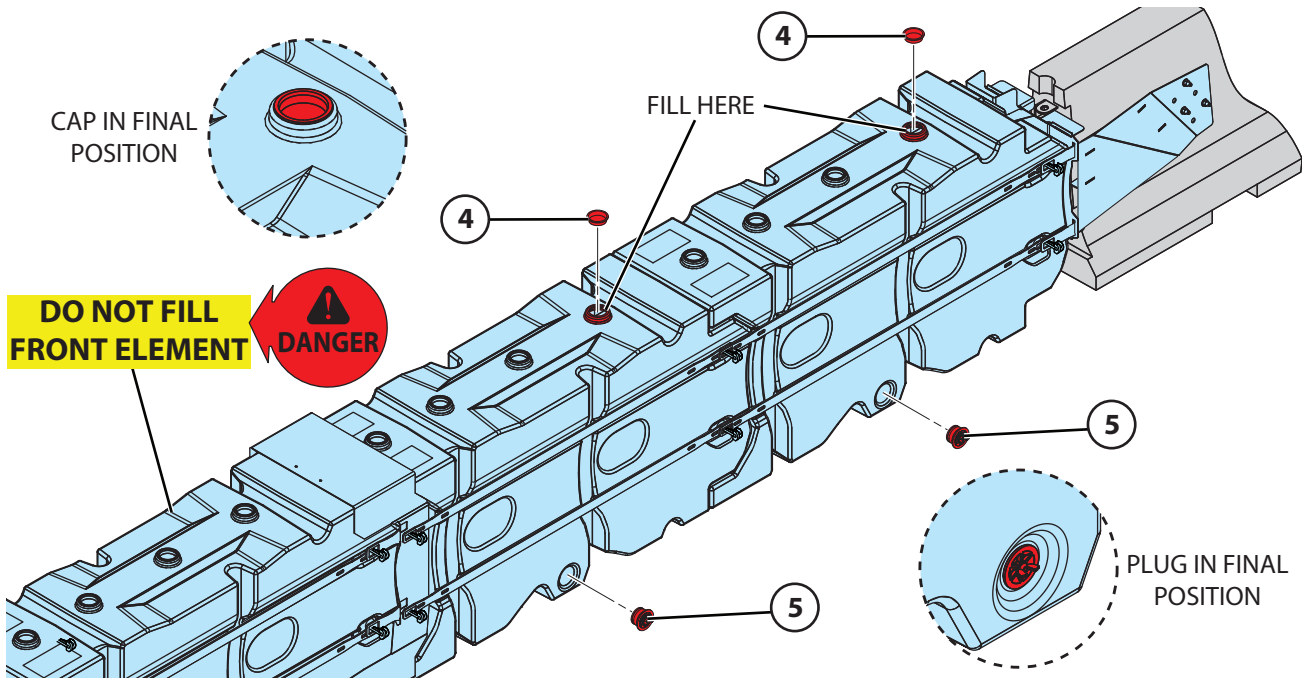

Item #	Part #	Description	TL-2	TL-3
4	BSI-4004494*	CAP	8	12
5	BSI-4004495*	PLUG	2	3

7.1 Ensure Plug (item 5) seated fully in the drain port. Rotate nut clockwise by hand until firmly secured.

NOTE: The plastic washer may become caught in the threads, preventing the wing nut from being fully tightened. Ensure plug is fully expanded, if washer obstructs threads loosen and re-tighten as needed.

7.2 Remove Cap (item 4) from the fill port of the rearmost Element(s) and complete fill with water. Approximately 250 gallons per Element.

7.3 Seat caps (item 4) fully.

7.4 Check the Plug at the drain port for leaks. Hand tighten Plug as needed if any leaking is observed.

⚠ DANGER ABSORB-M™ SYSTEM IS DESIGNED TO BE INSTALLED WITH THE FRONT ELEMENT ASSEMBLY (ELEMENT) ALWAYS EMPTY WITH REMAINING ELEMENT(S) FULL OF WATER. FAILURE TO DO SO WILL RESULT IN IMPROPER PERFORMANCE OF THE SYSTEM AND MAY CAUSE SERIOUS BODILY INJURY.

⚠ DANGER IN REGIONS WHERE THE WATER FILLED ELEMENTS COULD BECOME FROZEN, APPROPRIATE ANTI-FREEZE SOLUTIONS SHOULD BE USED. FAILURE TO DO SO WILL RESULT IN IMPROPER PERFORMANCE OF THE SYSTEM AND MAY CAUSE SERIOUS BODILY INJURY.

Care should be taken to ensure that appropriate Anti-Freeze solutions are used in accordance with federal, state, and local requirements. A few typical Anti-Freeze solutions are listed on page 27.

System Relocation

The ABSORB-M™ system is designed to be assembled with empty or full Elements. Although installation of the system prior to filling the Elements is preferred, the following instructions will allow the user to relocate a filled system with ease.

To transport empty Elements, first drain the water from the element by loosening the nut on the Plug and removing it from the drain port. Allow approximately five minutes for Element to drain completely. Crack the fill ports partially to improve drain flow.

Disassemble the elements by removing the pins. Store pins in separated elements for transport.

Users may transport the Transition while attached to the rear Element or the transition barrier. Both options are detailed on the following page.

Option 1 - Transition with the Barrier

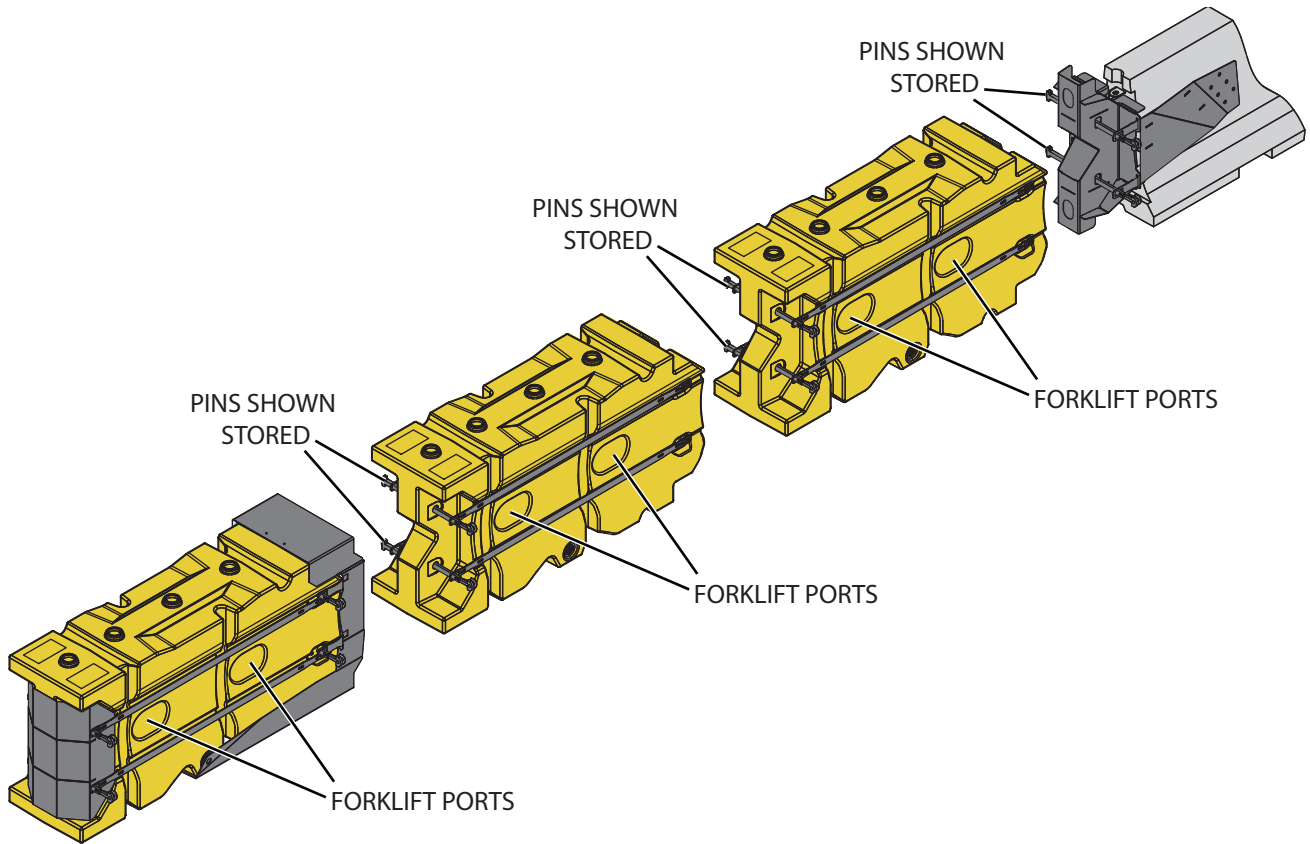

1. **Front Element, Nose Plate and Midnose:** connected with pins and lifted at the forklift holes.
2. **Middle and Rear Elements:** Transported individually. Pins can be stored in the locked position with the Elements.
3. **Transition Straps and Barrier:** Side Straps should remain secured to Transition Barrier. After rear element is removed, re-install the Pins to secure Transition to Transition Straps and Transition Barrier.

⚠ WARNING Do not stack water-filled Elements.

Option 2 - Transition with the Rear Element

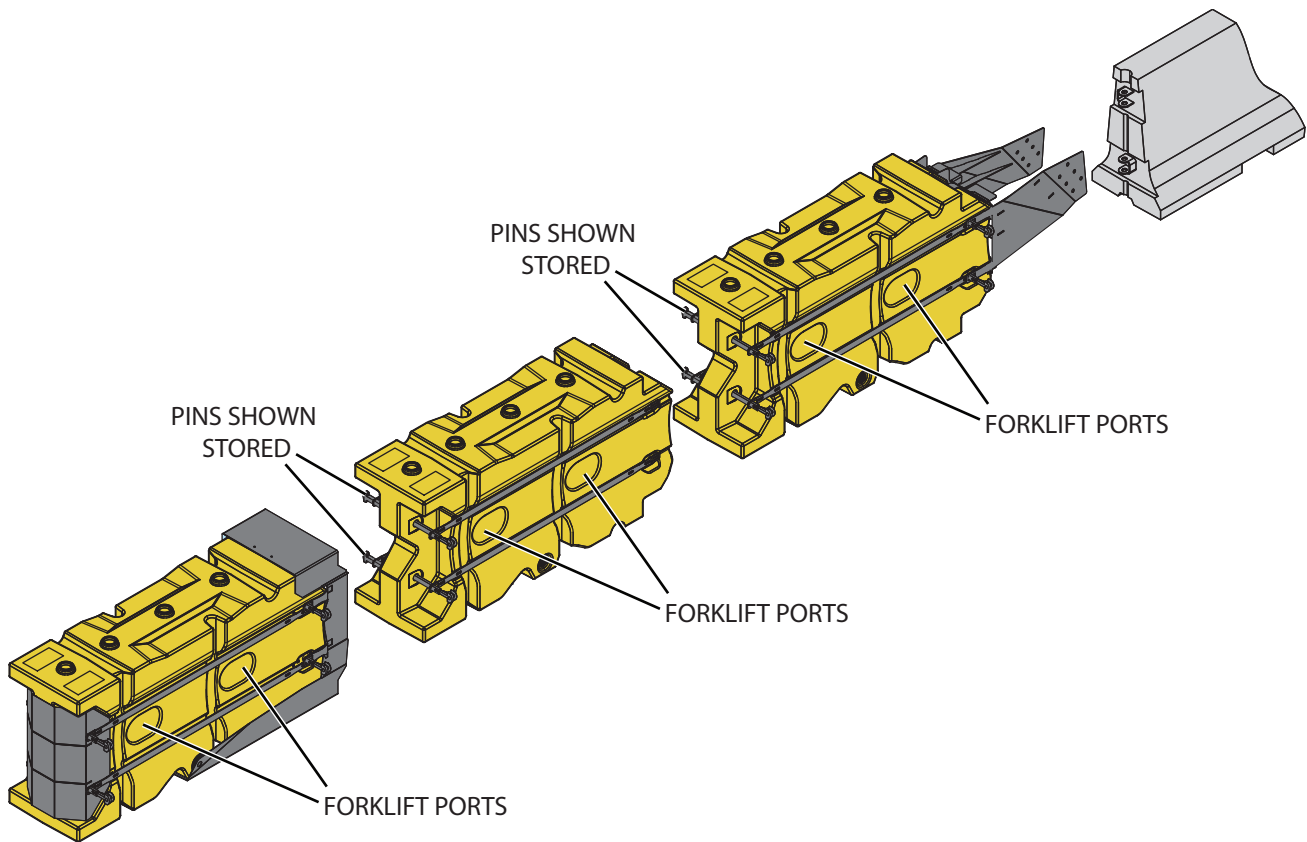

1. **Front Element, Nose Plate and Midnose:** connected with pins and lifted at the forklift holes.
2. **Middle Element:** Transported individually. Pins can be stored in the locked position with the Element.
3. **Transition and Rear Element:** Transition Straps should remain pinned to the rear Element. Unbolt from the transition Barrier and lift at the forklift holes.

⚠ WARNING Do not stack water-filled Elements.

Pro Tip: When lifting the rear barrier off the transition barrier, use a Pin as a spacer to keep the Transition Straps separated from the anchors.

Anti-Freeze Solutions

In regions where the water filled ABSORB-M™ Element(s) could become frozen, proper Anti-Freeze agents should be used. Care should be taken to ensure that proper Anti-Freeze agents are used in accordance with local regulations, environmental concerns and ensuring that any post impact liquid on the road surface does not constitute an undue hazard to adjacent motorists.

The information outlined in this document is intended to provide a general guide to ABSORB-M™ users for choosing, calculating, and applying Anti-Freeze solutions. The actual method and implementation of an Anti-Freezing solution should be determined by federal, state and local standards and in accordance with the specific manufacturer's instructions.

Considerations for choosing an Anti-Freeze should include environmental impact on local vegetation and waterways, corrosion of existing structures, and the effect on concrete or asphalt roadways. Transportation, installation, and handling of the material should also be considered. The examples listed below are products commonly used on highways as de-icing road and bridge conditioners and for dust control. Specific information pertaining to these products regarding said considerations should be readily available from the product supplier or manufacturer.

The correct mixture of Anti-Freeze and water is critical to insure proper ice prevention and performance of the ABSORB-M™ crash cushion. The freezing capacity depends on the particular chemical and the solution concentrate by percent weight of the solution. Both too little and too much solution will result in diminished freezing capacity. The ideal solution concentration for maximum capacity is specific to the chemical chosen. It may be desirable to reduce the concentration for cost savings if the maximum capacity is not necessary.

Depending on the form the chemical is provided; such as a fluid, powder, or pellet; the actual amount of the desired chemical may not constitute 100% of the material by weight. It is important to account for the actual weight of the deicing chemical when mixing the solution.

Typical solution concentrations are listed in the table on page 27. Some of the following are available as a fluid solution of definite concentration or pellets and flakes in various sized bags. If purchased in flake or pellet form, care must be taken in dissolving it in water. Also, the concentrate must be calculated from the actual Anti-Freeze agent content. For example, if the flake/pellet agent purchased has a Calcium Chloride content of 80% and a 29% solution by weight is desired, the quantity added must account for the impurity of the agent. These principles apply to many various Anti-Freezing chemicals.

Table of Typical Anti-Freeze Solutions

Anti-Freeze Agent	Concentration, %	Operating Temp, °F [°C]
Calcium Chloride (CaCl ₂)	29%	-51 [-60]
Liquid CMA (Calcium Magnesium Acetate)	33%	-28 [-18]
Magnesium Chloride (MgCl ₂)	22%	-33 [-28]
Sodium Chloride (NaCl)	23%	-21 [-6]
Liquid Potassium Acetate (KAc)	49%	-60 [-76]

Single Element Capacity

Liquid Capacity, gal [L]	Water Weight, lb [kg]
250 [946]	2,086 [946]

Anti-Freeze Chemical Companies

The following companies are manufacturers of deicing chemicals. These are just a few examples. These companies or their local distributors should be able to supply further information and options for your application.

Dow Chemical Company

USA or Canada (800)-447-4369

Worldwide (989)-832-1466

www.dow.com

Contact for local Distributor, or find on Web Site

Cargill Salt

(888)-385-7258

Highway and Specialty Deicing Customer Service (800)-600-7258

www.cargillsalt.com

Contact for information and distribution

Cryotech Deicing Technology

Main Office and Plant – Iowa (800)-346-7237

www.cryotech.com

Contact for information, Branch Offices, and distribution

Transportation and Storage

When empty, Elements are designed to be transported and stored in stacks of up to two high. Careful attention should be paid to aligning the fill ports with the reciprocal recess at the bottom of each Element. The raised fill ports will prevent shifting during transit.

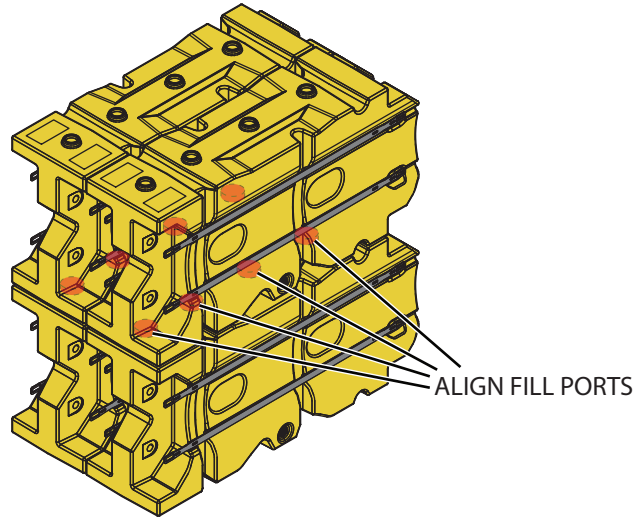

⚠ WARNING Elements that have not been drained completely should not be stacked.

Inspector Checklist

Confirm all items in the checklist have been properly completed and hardware installed properly.

Installation Checklist		
Date	Initial	Item
		Midnose is under the front Element, connected by two (2) pins, and attached to the next element by two (2) Pins. (Step 3, Page 18)
		Nose Plate is attached to front Element by two (2) Pins. (Step 4, Page 19)
		(TL-3 only) Middle and rear Elements connected by two (2) Pins. (Step 5, Page 20)
		Rear Element connected to Transition and both Transition Straps by two (2) Pins. (Step 5, Page 20)
		Transition Straps secured to the Transition Barrier with at least three (3) Anchors on each side. (Step 6, Page 21)
		Anchors torqued to 60 ft-lbf [80 N-m]. (Step 6, Page 21)
		Front Element empty. (Step 7, Page 22)
		Rear Element(s) full of water. (Step 7, Page 22)
		Visually inspect elements all around to ensure no leaks.
		Plug at drain ports fully seated and secure with no sign of leakage. (Step 7, Page 22)
		Caps at fill ports are fully seated. (Step 7, Page 22)
Cold Weather Applications Only		
		Anti-Freeze solution applied in accordance with manufacturer's specifications.

Inspector signature: _____ Date: _____

Maintenance Inspection

Crash cushions, like all roadside safety hardware, require inspection to ensure they are in acceptable working condition. Regular inspections of the ABSORB-M™ system is recommended and shall be made by the local highway authority. Frequency of the inspections shall be made based on site conditions, traffic volumes, and crash history. Please follow the Local guidelines for frequency of inspections to ensure adequate repairs are made to the system. Walk-up inspections are recommended at least twice a year.

Walk-Up Inspections

Recommended Frequency – Twice a Year

Before performing walk-up inspections, ensure traffic control is deployed in accordance with local guidelines.

Check for:

- Water level is within 2" of the top of the Element's fill ports.
- Front element is empty
- Damage caused by vehicle impacts
- Damage caused by impacts from roadside maintenance equipment
- Misalignment
- Missing components
- Vandalism
- Clear and dispose of any debris in and around the system

After inspection is complete, ensure all items identified during the inspection process are corrected. The ABSORB-M™ system shall be returned to proper condition as outlined in the installation instructions.

Walk-Up Inspection	
Item	Comment
Water level is within 2" of the top.	
Front element is empty	
Damage caused by vehicle impacts	
Minor damage caused by impacts from roadside maintenance equipment	
Misalignment	
Missing components	
Vandalism	
Clear and dispose of any debris in and around the system	
Grading around system	
Inspector Signature:	Date:
Print Name:	Location:

Drawings (Cont.)

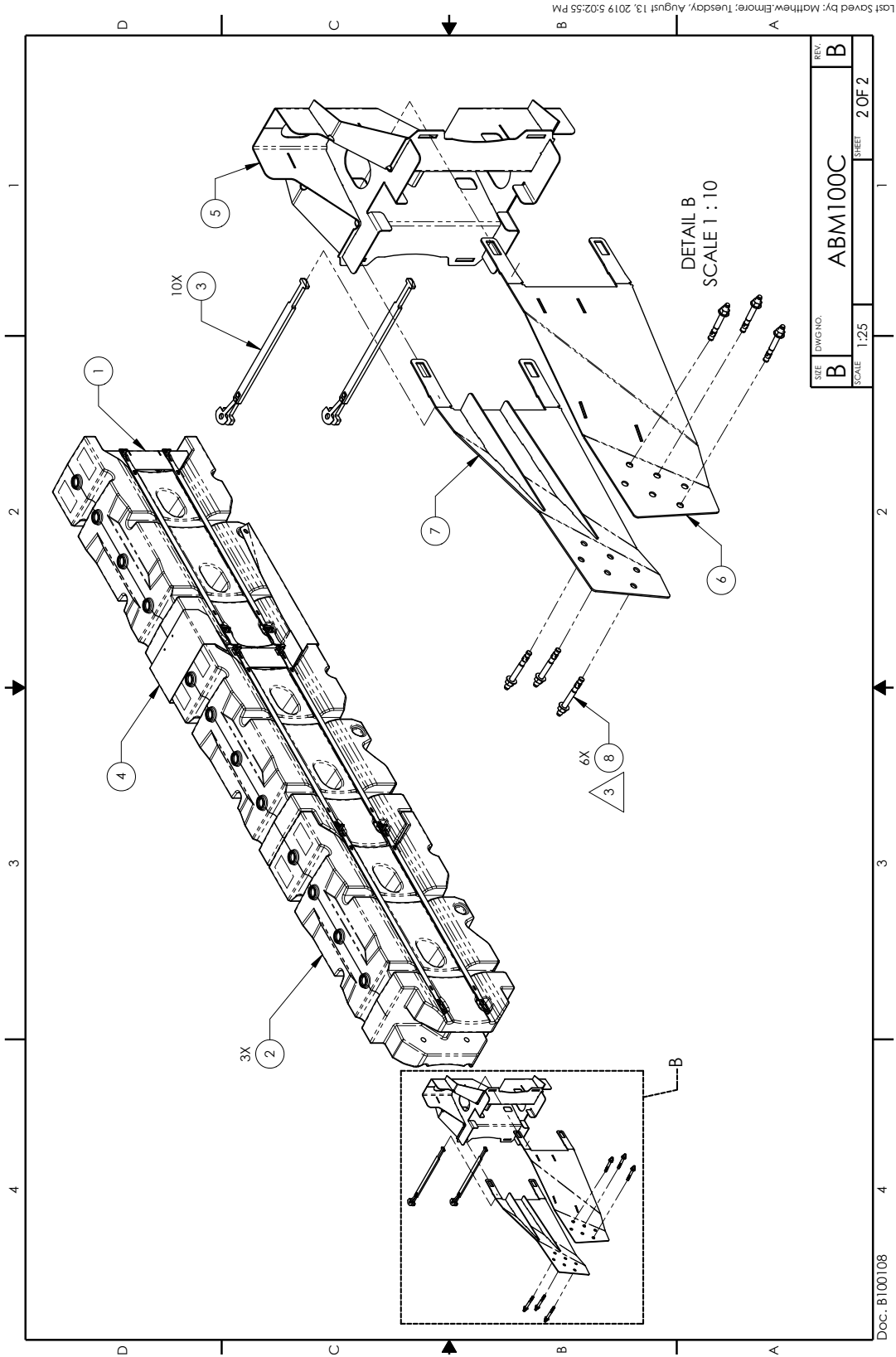

Last Saved by: Mathew Elmore; Tuesday, August 13, 2019 5:02:55 PM

Drawings (Cont.)

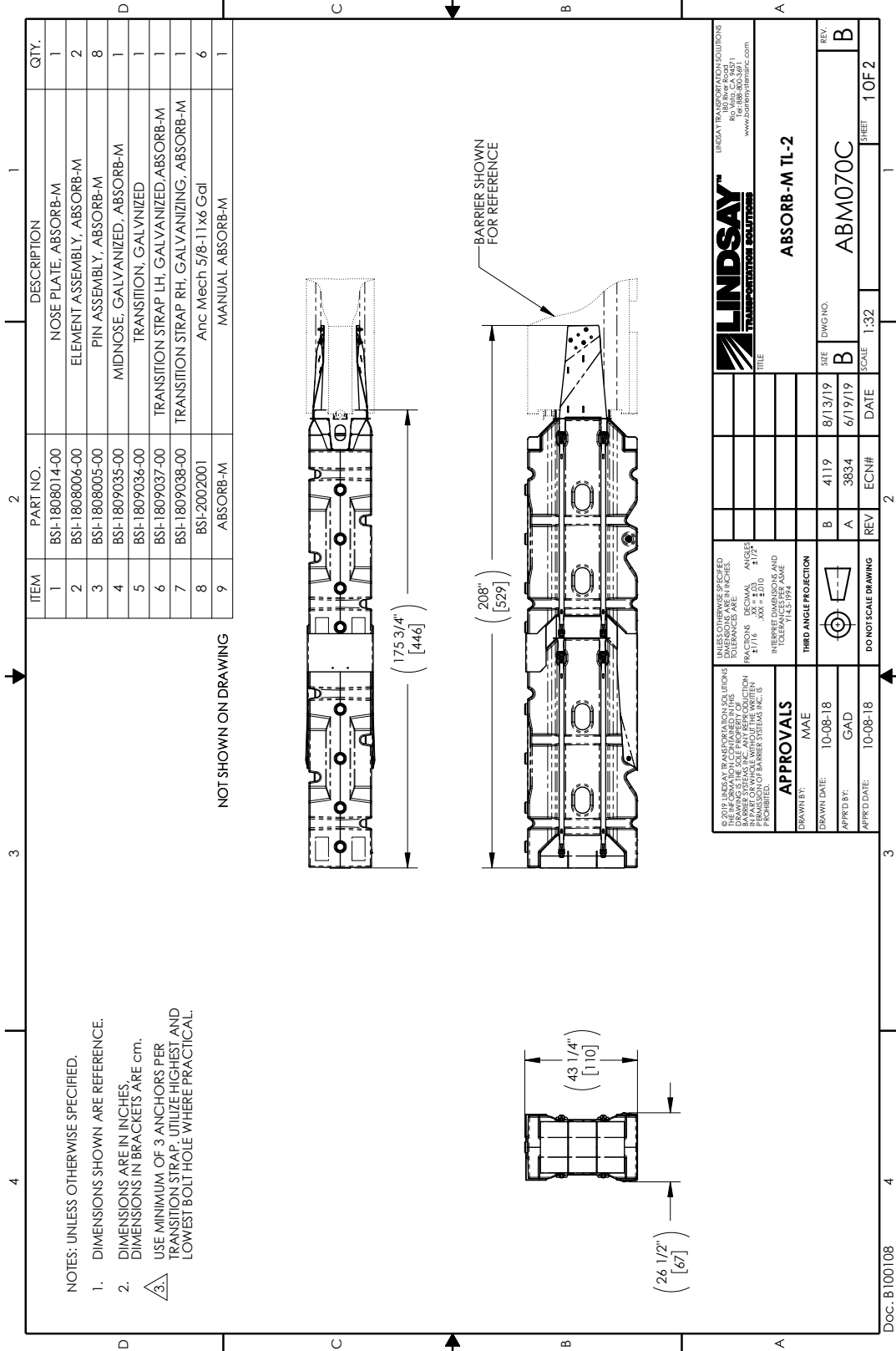

Last Saved by: Matthew Elmore; Tuesday, August 13, 2019 4:55:28 PM

LINDSAY
 TRANSPORTATION SOLUTIONS
 TITLE: ABSORB-M TL-2

UNLESS OTHERWISE SPECIFIED, DIMENSIONS ARE IN INCHES. DIMENSIONS IN BRACKETS ARE IN MILLIMETERS. ANGLES ARE IN DEGREES. TOLERANCES PER ASME Y14.5-1994

APPROVALS
 DRAWN BY: MAE
 DRAWN DATE: 10-08-18
 APP'D BY: GAD
 APP'D DATE: 10-08-18

DO NOT SCALE DRAWING

REV	DATE	ECN#	REV
B	8/13/19	4119	B
A	6/19/19	3834	A

SCALE: 1:32
 DWG NO: ABM070C
 SHEET 1 OF 2

Doc: B100108

Drawings (Cont.)

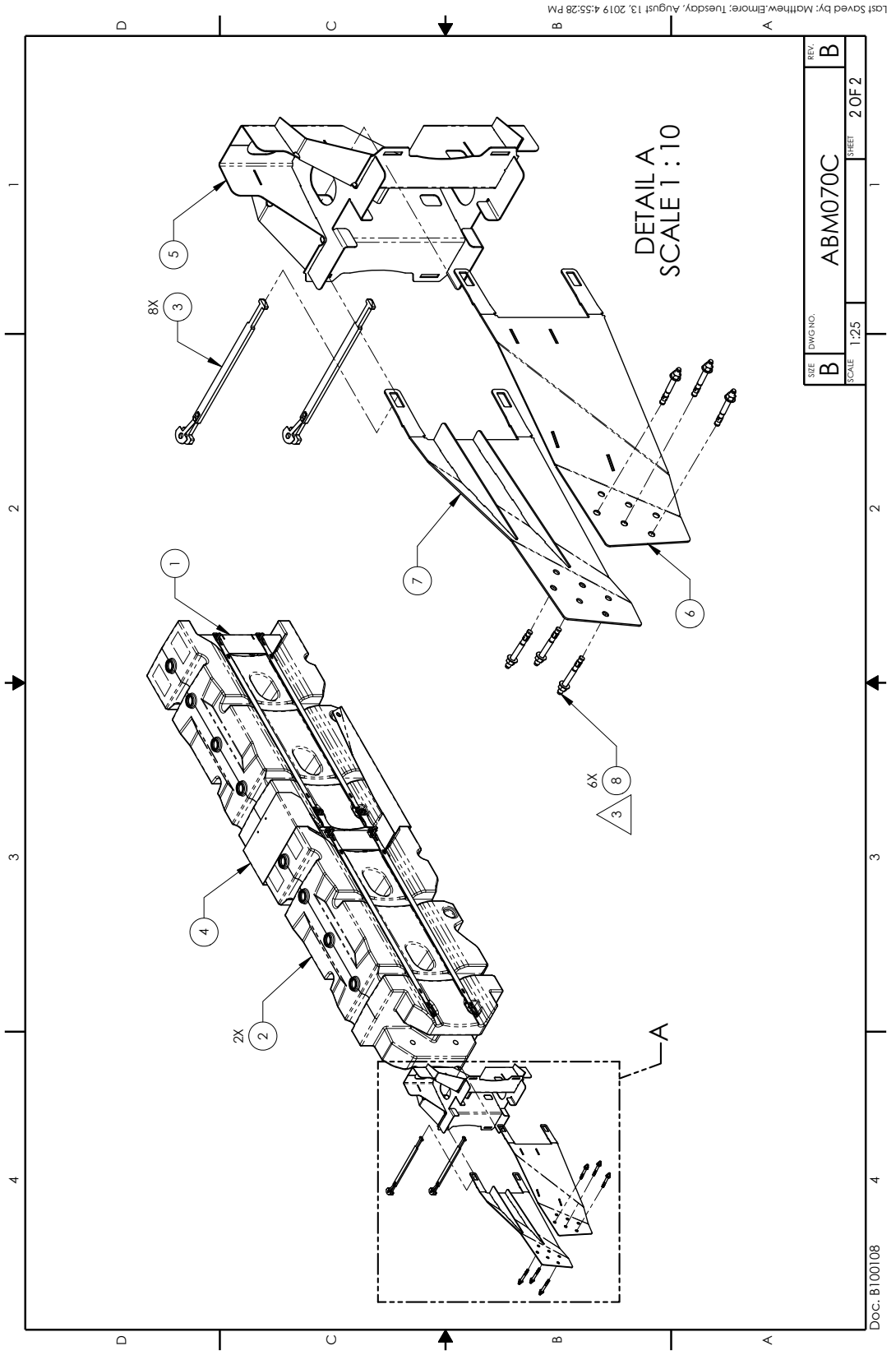

Last Saved by: Matthew.Elmore; Tuesday, August 13, 2019 4:55:28 PM

Long-Term Storage

⚠ WARNING Do not stack full elements.

Fill caps should be fully seating to prevent water from accumulating inside the elements.

Store materials under cover in dry, well-ventilated conditions, away from doorways open to the environment.

Provide adequate ventilation between stacked metal pieces. Elevate and separate metal articles stacked outdoors with spacers (poplar, ash, spruce).

Incline parts to allow for maximum drainage.

Avoid stacking material directly on soil or decaying vegetation.

For crated items, remove the lids to provide better ventilation and drying of the galvanized parts. Customers will need to remove kits packed in cardboard boxes from the crates and store them inside.

NOTES

NOTES



Copyright © 2019-2024 Lindsay. All rights reserved.

This book or any portion thereof may not be reproduced or used in any manner whatsoever without the express written permission of the publisher.

The content of this document is furnished for informational purposes only, is subject to change without notice, and should not be construed as a commitment by Lindsay Transportation Solutions. Lindsay Transportation Solutions assumes no responsibility or liability for errors or inaccuracies that may appear in the informational content of this document.

For further information, including Lindsay patents: <http://www.lindsay.com>

It is your and your employers' responsibility to comply with all applicable local and national safety codes and standards, including but not limited to the requirements of the U.S. Occupational Safety and Health Administration (OSHA), the National Fire Protection Association (NFPA) (including but not limited to the NFPA 70: National Electrical Code (NEC) and NFPA 70E), and other appropriate governmental and industry accepted guidelines, codes, and standards in their entirety.



Lindsay Transportation Solutions, LLC
18135 Burke Street Suite 100. Omaha, NE 68022
+1 402.829.6800 U.S. Toll Free: 888.800.3691 • www.lindsay.com

P/N ABSORB-M Rev D (ECN 62817)